

# T20-81-29

REV. 8/06

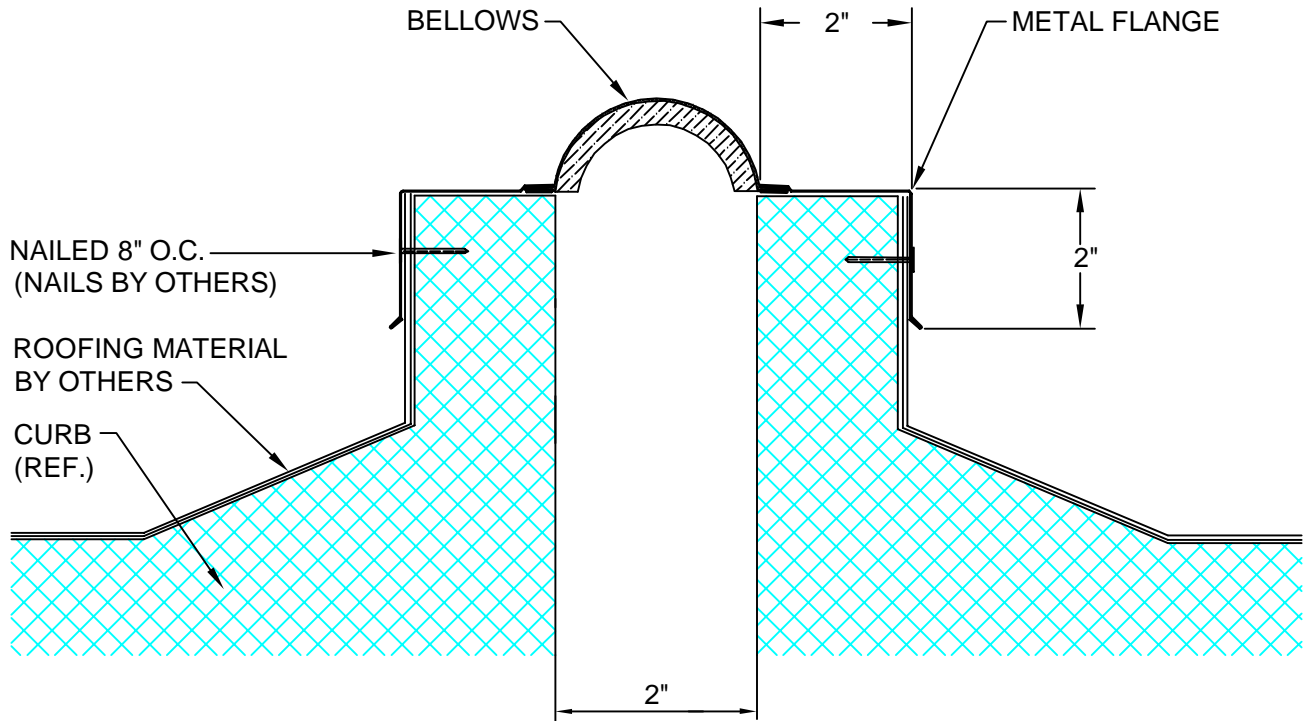

DESCRIPTION: ROOF-TO-ROOF BELLOWS  
 FLANGE: .018" STAINLESS STEEL  
 BELLOWS: 60 MIL BLACK EPDM  
 EXPOSED FINISH: MILL  
 ALLOWABLE LOAD: NOT DESIGNED FOR STRUCTURAL LOADS  
 MOVEMENT: +/- 100% JOINT WIDTH  
 STOCK LENGTH: 10'-0"

CUSTOMER:		
PROJECT:		
LOCATION:		
ARCHITECT:		
CONTRACTOR:		
NOTE:		
JOB NO.:	DATE:	SCALE: (NTS)

LENGTH:	QTY:	COLOR/FINISH:



**ARCHITECTURAL ART MFG., INC.**

6409 RHODE ISLAND AVE. RIVERDALE, MD 20737

