

#10-24 x 5/8"  
S.S. P.F.H.M.S.  
@ 24" O.C.

TF250 FRAME

CONT. "O" RING  
VINYL SEALS

1/4" x 2 3/4"  
H.H. BOLT  
@ 18" O.C.

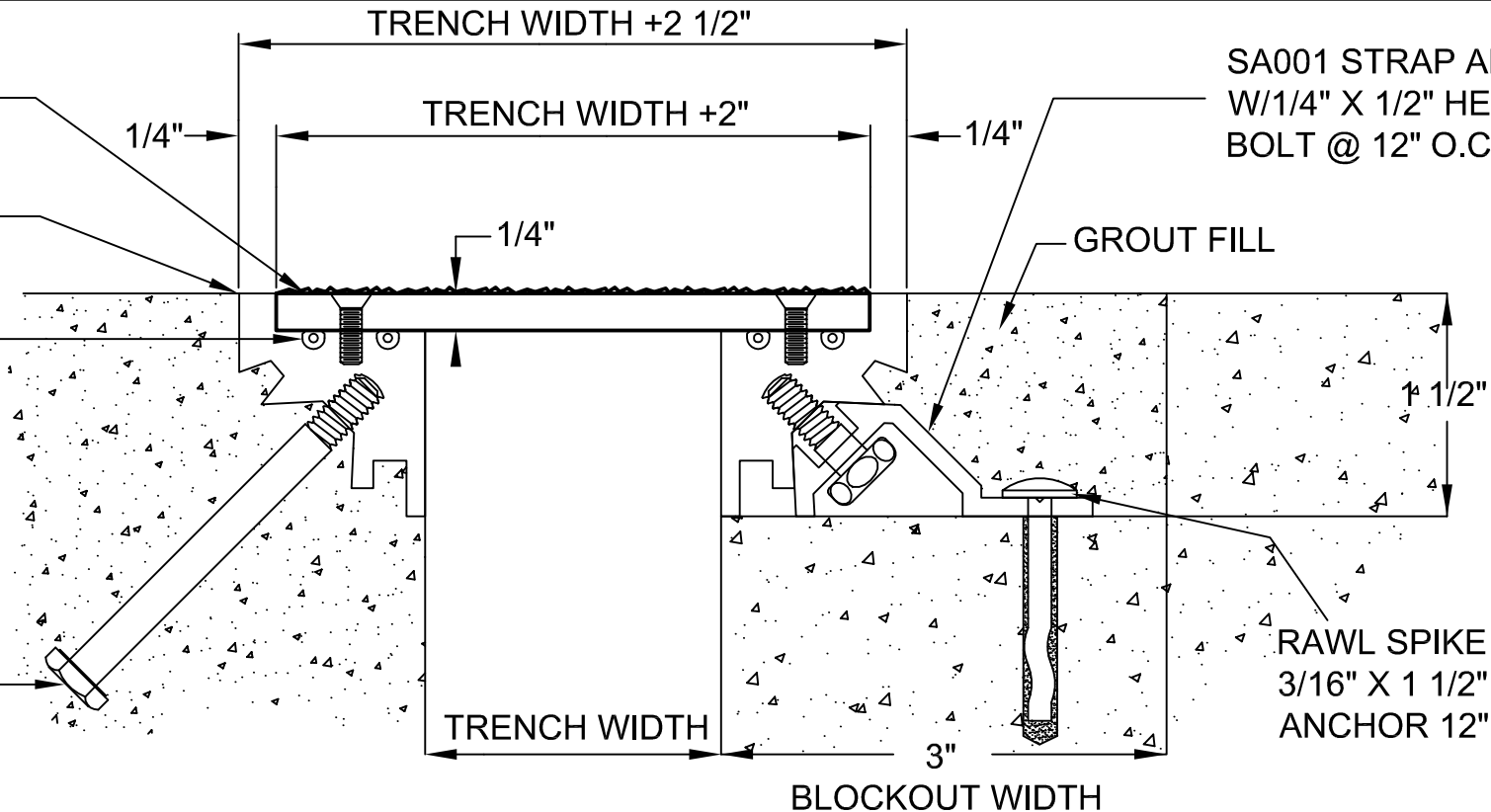

SA001 STRAP ANCHOR  
W/1/4" X 1/2" HEX HEAD  
BOLT @ 12" O.C.

GROUT FILL

RAWL SPIKE  
3/16" X 1 1/2"  
ANCHOR 12" O.C.

BLOCKOUT WIDTH

\*CAST IN PLACE MOUNT - STANDARD

\*BLOCKOUT MOUNT OPTION

Select Mounting Option:

Cast-in Place: \_\_\_\_\_ (Standard if no selection is made)

Block-out: \_\_\_\_\_

ALUMINUM: 6063-T5 EXTRUSION, 6061-T6

EXPOSED FINISH: MILL

ZINC CHROMATE AREAS IN CONTACT W/CONCRETE

ALLOWABLE LOAD: CALL FACTORY: 800-835-0028

SEALS: 70 DURO. VINYL

ABRASIVE: BLACK ABRASIVE GRIT ON HIGH-BONDING,

PRESSURE-SENSITIVE ADHESIVE

**M00-11-14**

REV. 06/09



**Architectural Art**  
MANUFACTURING

Division of Pittcon Architectural Metals, LLC

283 SWANSON DRIVE, STE 103  
LAWRENCEVILLE, GA 30043  
PH: (678) 680-7373 FAX: (678) 735-0085  
TOLL FREE: (800) 835-0028 web: www.archart.com

**BLACK ABRASIVE PLATE TRENCH**

MODEL: M00-11-14

DRAWN BY:  
JMT

SCALE:  
NTS

DRAWING NO.:

**DTL-01**

SHT. 1 OF 1

ISSUE DATE:  
11/24/08

NO.	DESCRIPTION	BY	DATE

REVISIONS

The information contained herein is the proprietary property of **ARCHITECTURAL ART MFG.**, Division of Pittcon Architectural Metals, LLC. No portion of it may be reproduced by any means or used in any form except for the purpose for which it was furnished. All rights of design and invention are hereby reserved. We reserve the right to make changes in the design at our discretion.