

H40-63-22

REV. 8/06

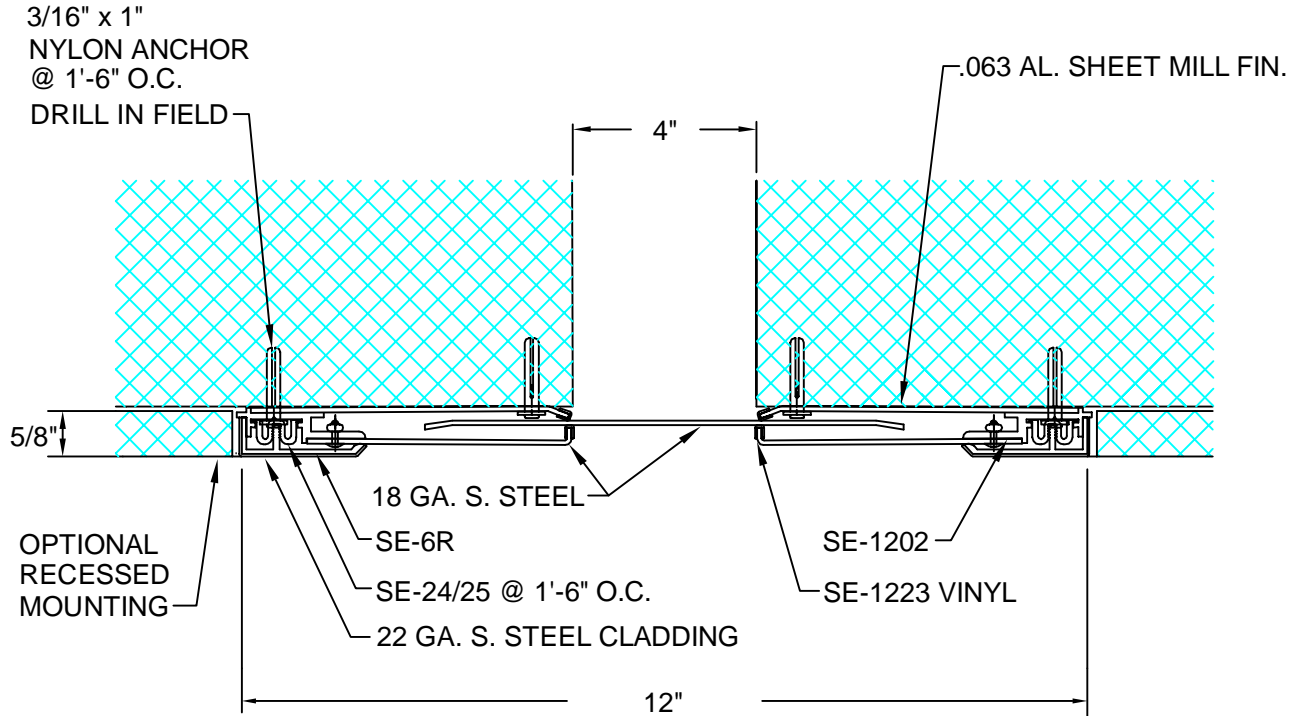

DESCRIPTION: INTERIOR FLAT WALL/CEILING

ALUMINUM: 6063-T5 EXTRUSION, 3003-H14 SHEET

STAINLESS STEEL: 304 ALLOY

VINYL: 90 DURO PVC

EXPOSED FINISH: #4 SATIN W/ STRIPPABLE PROTECTIVE TAPE

ALLOWABLE LOAD: NOT DESIGNED FOR STRUCTURAL LOADS

MOVEMENT: +/- 50% JOINT WIDTH

STOCK LENGTHS: 10'-0"

CUSTOMER:		
PROJECT:		
LOCATION:		
ARCHITECT:		
CONTRACTOR:		
NOTE:		
JOB NO.:	DATE:	SCALE: (NTS)

LENGTH:	QTY:	COLOR/FINISH:



ARCHITECTURAL ART MFG., INC.

6409 RHODE ISLAND AVE. RIVERDALE, MD 20737

