

H40-63-11

REV. 8/06

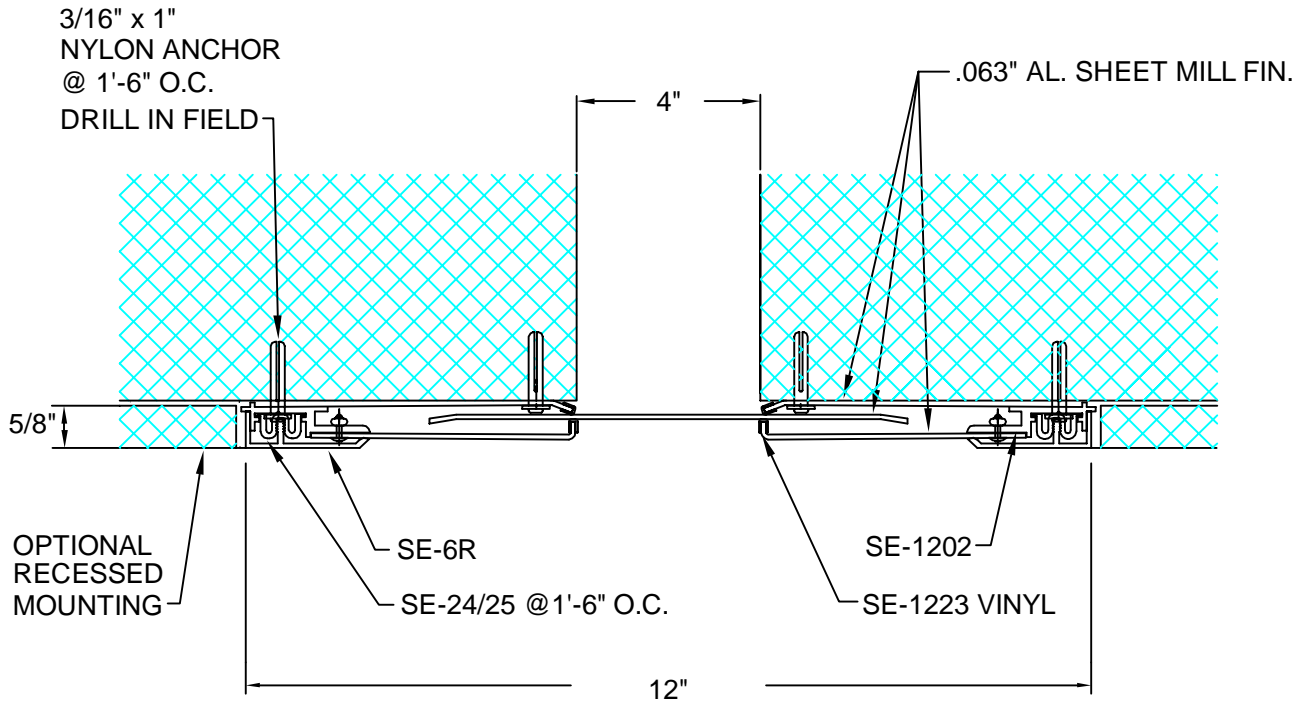

DESCRIPTION: INTERIOR FLAT WALL/CEILING
 ALUMINUM: 6063-T5 EXTRUSION, 3003-H14 SHEET
 VINYL: 90 DURO. PVC
 EXPOSED FINISH: MILL W/ STRIPPABLE PROTECTIVE TAPE
 ALLOWABLE LOAD: NOT DESIGNED FOR STRUCTURAL LOADS
 MOVEMENT: +/- 50% JOINT WIDTH
 STOCK LENGTHS: 10'-0"

CUSTOMER:			LENGTH:	QTY:	COLOR/FINISH:
PROJECT:					
LOCATION:					
ARCHITECT:					
CONTRACTOR:					
NOTE:					
JOB NO.:	DATE:	SCALE: (NTS)			



ARCHITECTURAL ART MFG., INC.

6409 RHODE ISLAND AVE. RIVERDALE, MD 20737

