

D10-52-32

REV. 7/06

DS060-1-1 S.S.
SPRING ASSEMBLY @ 1'-6" O.C.

3/16" x 1 3/4" F.H. TAPCON
2'-0" O.C. FACTORY DRILLED

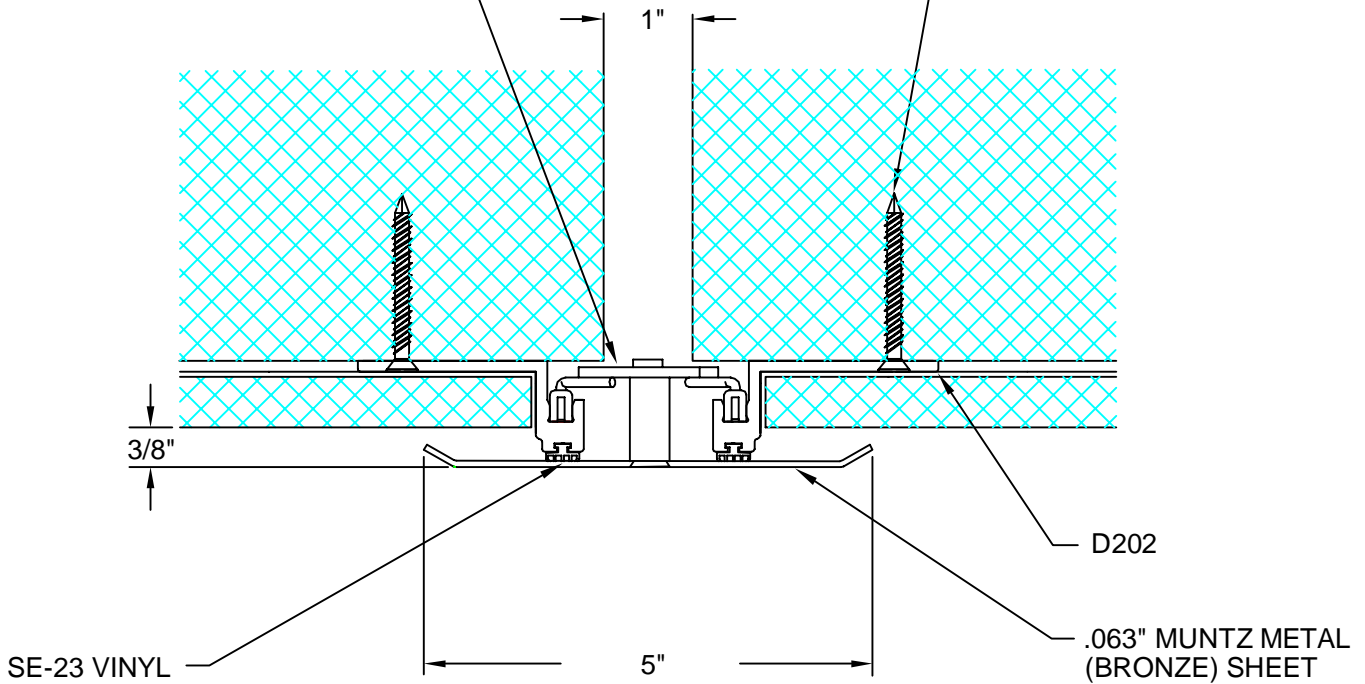

DESCRIPTION: INTERIOR FLAT WALL/CEILING
 ALUMINUM: 6063-T5 EXTRUSION
 BRONZE: 280 ALLOY MUNTZ METAL
 EXPOSED FINISH: #4 SATIN W/ STRIPPABLE PROTECTIVE TAPE
 ALLOWABLE LOAD: NOT DESIGNED FOR STRUCTURAL LOADS
 MOVEMENT: +/- 50% JOINT WIDTH
 STOCK LENGTHS: 10'-0"

CUSTOMER:		
PROJECT:		
LOCATION:		
ARCHITECT:		
CONTRACTOR:		
NOTE:		
JOB NO.:	DATE:	SCALE: (NTS)

LENGTH:	QTY:	COLOR/FINISH:

ARCHITECTURAL ART MFG., INC.
 6409 RHODE ISLAND AVE. RIVERDALE, MD 20737