

C10-64-44

REV. 3/07

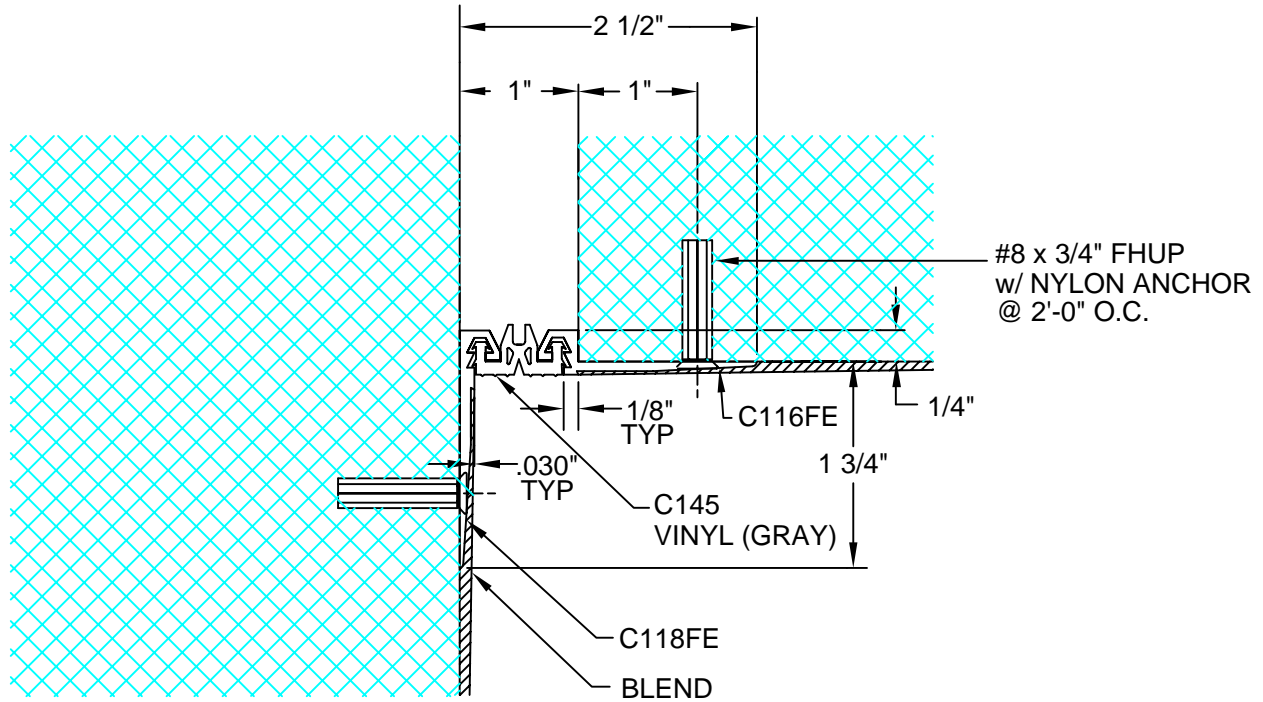

DESCRIPTION: WALL TO CORNER; CEILING TO WALL GYP. BD.
 ALUMINUM: 6063-T5 EXTRUSION
 VINYL: 70 DURO PVC
 EXPOSED FINISH: MILL
 ALLOWABLE LOAD: -NOT DESIGNED FOR STRUCTURAL LOADS-
 MOVEMENT: +/- 25% JOINT WIDTH
 STOCK LENGTHS: 20'-0"

CUSTOMER:		
PROJECT:		
LOCATION:		
ARCHITECT:		
CONTRACTOR:		
NOTE:		
JOB NO.:	DATE:	SCALE: (NTS)

LENGTH:	QTY:	COLOR/FINISH:

ARCHITECTURAL ART MFG.

6409 RHODE ISLAND AVE. RIVERDALE, MD 20737 PHONE (800) 835-0028 FAX (316) 462-0511 WWW.ARCHART.COM

AAM RESERVES THE RIGHT TO MAKE DESIGN CHANGES, OR TO WITHDRAW ANY DESIGN WITHOUT NOTICE

© COPYRIGHT 2007 AAM