

COLOR SELECTOR	
BLACK _____	BROWN _____
BEIGE _____	GRAY _____
WHITE _____	

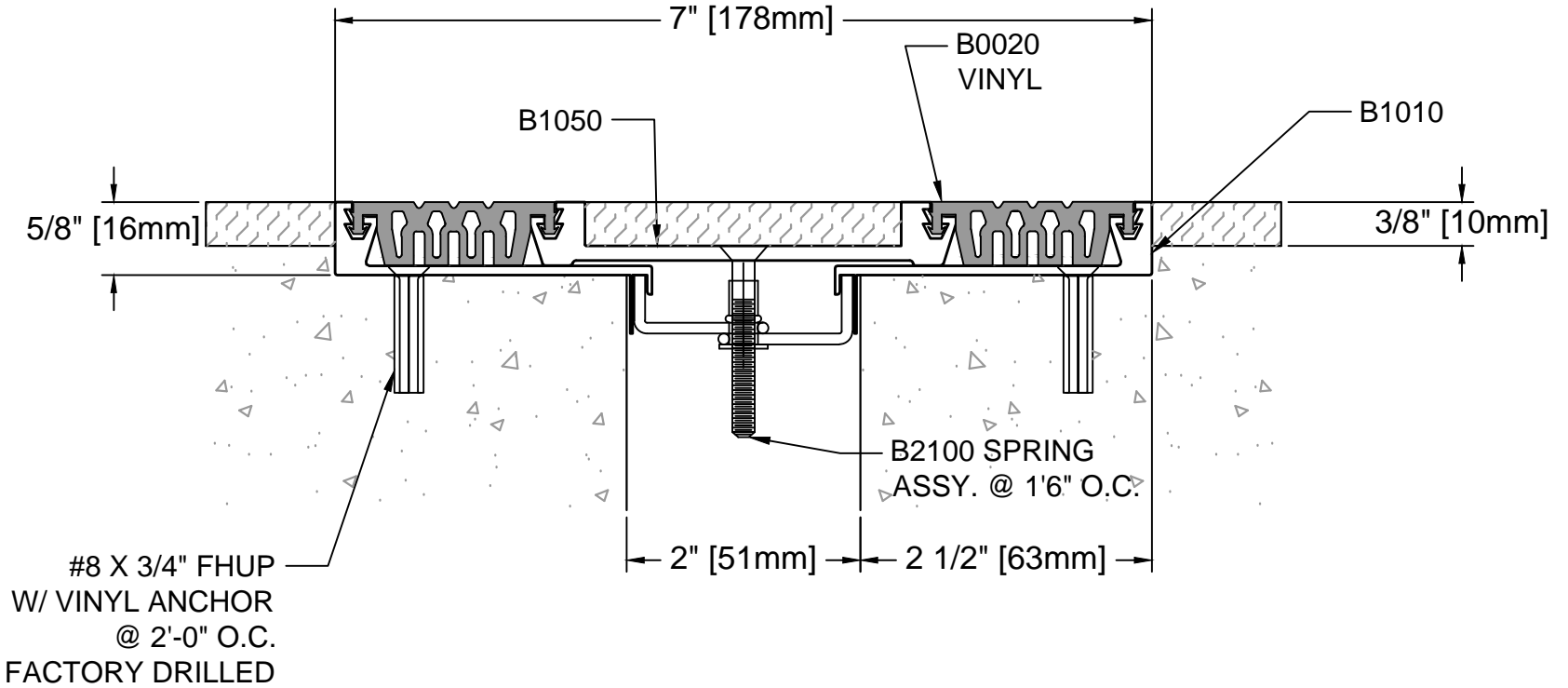

DESCRIPTION: FLOOR-TO-FLOOR  
 ALUMINUM: 6063-T5 EXTRUSION  
 FINISH: MILL  
 ALLOWABLE LOAD: 738 LB/LF @ MAX. OPENING  
 MOVEMENT: +/- 50% JOINT WIDTH  
 STOCK LENGTHS: 20'-0"

**B20-18-11**  
 REV. 08/08

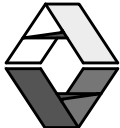

**Architectural Art**  
 MANUFACTURING

Division of Pittcon Architectural Metals, LLC  
 283 SWANSON DRIVE, STE 103  
 LAWRENCEVILLE, GA 30043  
 PH: (678) 680-7373 FAX: (678) 735-0085  
 TOLL FREE: (800) 835-0028 web: www.archart.com

**FLOOR-FLOOR JOINT COVER**

MODEL: B20-18-11		
DRAWN BY: NDC	SCALE: NTS	DRAWING NO.:
SHT. 1 OF 1	ISSUE DATE: 08/06/2009	<b>DTL-01</b>

NO.	DESCRIPTION	BY	DATE

**REVISIONS**

The information contained herein is the proprietary property of **ARCHITECTURAL ART MFG.**, Division of Pittcon Architectural Metals, LLC. No portion of it may be reproduced by any means or used in any form except for the purpose for which it was furnished. All rights of design and invention are hereby reserved. We reserve the right to make changes in the design at our discretion.