

B10-31-16

REV. 7/06

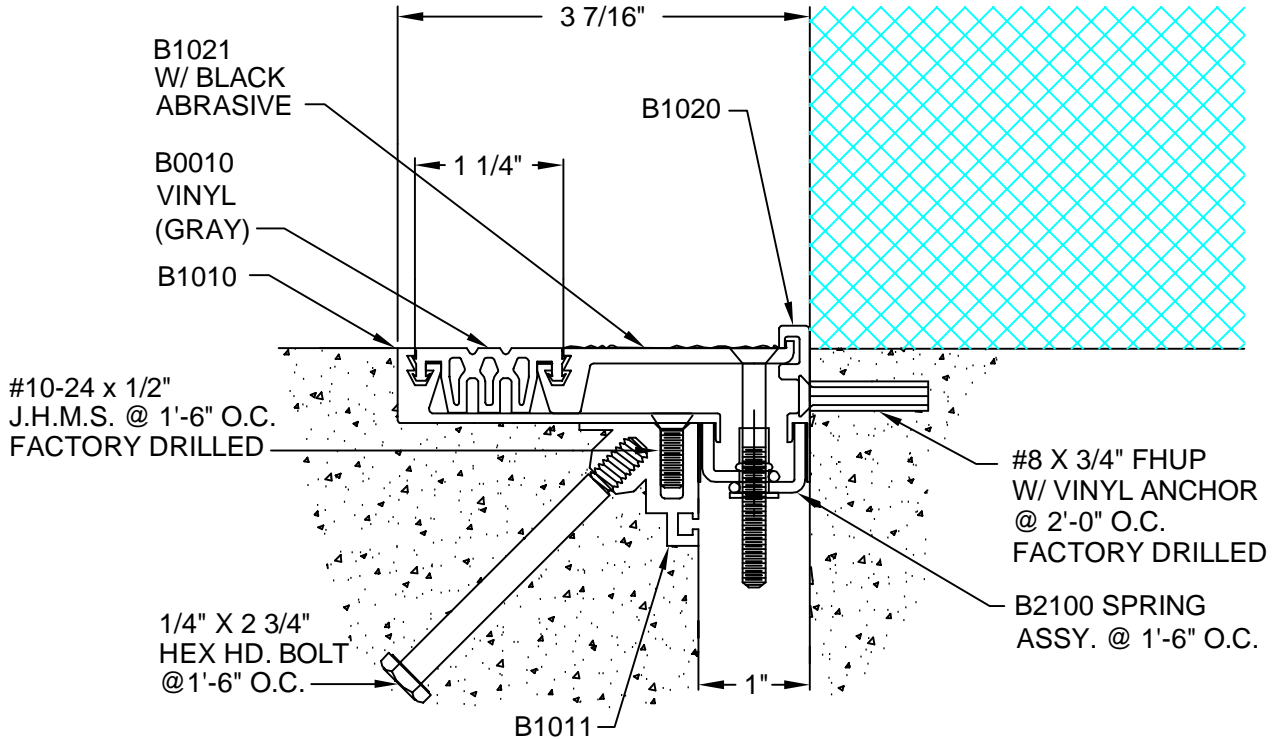

DESCRIPTION: FLOOR-TO-WALL
 ALUMINUM: 6063-T5 EXTRUSION
 VINYL: 70 DURO. PVC
 EXPOSED FINISH: MILL
 ABRASIVE: BLACK ABRASIVE GRIT ON
 HIGH- BONDING, PRESSURE-
 SENSITIVE ADHESIVE
 ZINC CHROMATE IN AREAS W/ WET CEMENT
 ALLOWABLE LOAD: 1891 LB/LF @ MAX OPENING
 MOVEMENT: +/- 25% JOINT WIDTH
 STOCK LENGTHS: 20'-0"

CUSTOMER:		
PROJECT:		
LOCATION:		
ARCHITECT:		
CONTRACTOR:		
NOTE:		
JOB NO.:	DATE:	SCALE: (NTS)

LENGTH:	QTY:	COLOR/FINISH:



ARCHITECTURAL ART MFG., INC.
 6409 RHODE ISLAND AVE. RIVERDALE, MD 20737

