

# B10-15-11

REV. 7/06

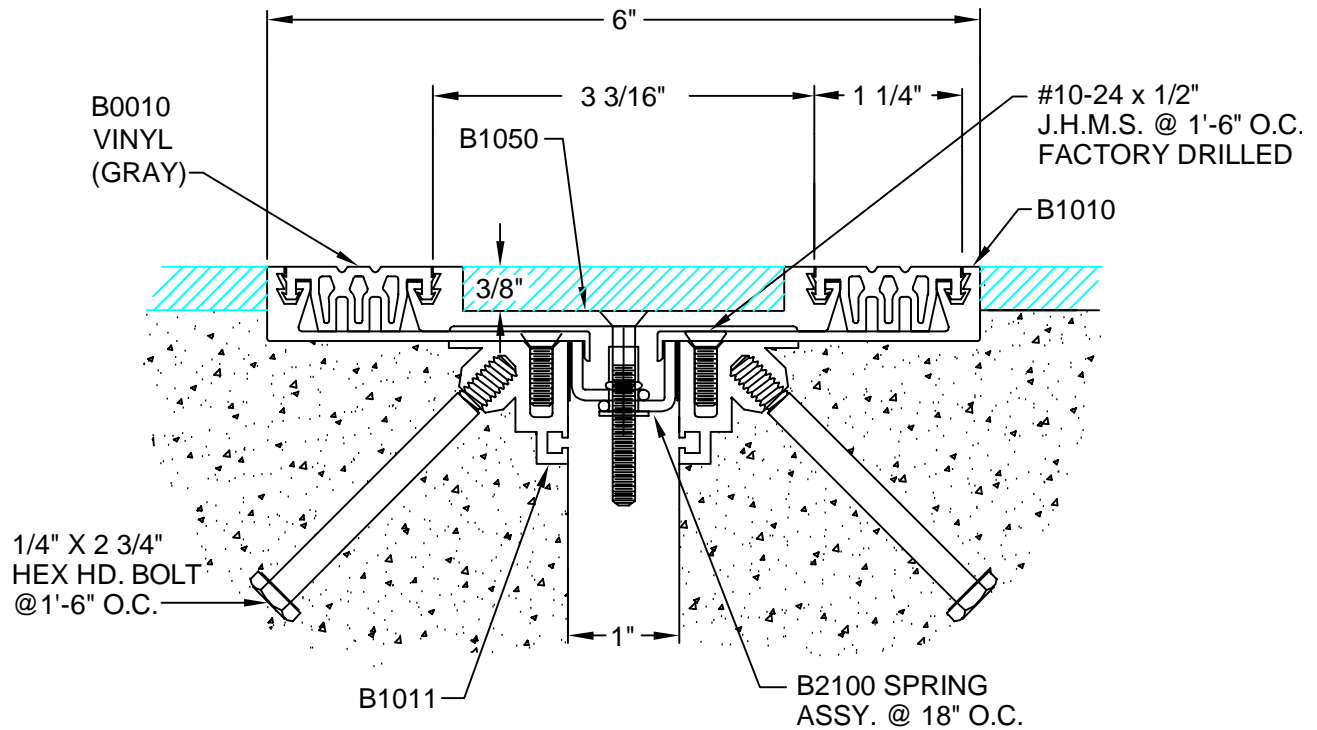

**DESCRIPTION:** FLOOR-TO-FLOOR  
**ALUMINUM:** 6063-T5 EXTRUSION  
**VINYL:** 70 DURO. PVC  
**EXPOSED FINISH:** MILL  
**ZINC CHROMATE AREAS IN CONTACT W/ WET CEMENT**  
**ALLOWABLE LOAD:** 738 LB/LF @ MAX. OPENING  
**MOVEMENT:** +/- 50% JOINT WIDTH  
**STOCK LENGTHS:** 20'-0"

<b>CUSTOMER:</b>		
<b>PROJECT:</b>		
<b>LOCATION:</b>		
<b>ARCHITECT:</b>		
<b>CONTRACTOR:</b>		
<b>NOTE:</b>		
<b>JOB NO.:</b>	<b>DATE:</b>	<b>SCALE: (NTS)</b>

LENGTH:	QTY:	COLOR/FINISH:

**ARCHITECTURAL ART MFG., INC.**  
 6409 RHODE ISLAND AVE. RIVERDALE, MD 20737